



Life Science Products

The LYNX mission is to provide Animal Care Washing Systems of the highest standards, quality, and reliability in the industry. Our service and customer care will be unmatched.

Model 495LX Cage and Rack Washer

The LYNX Model 495LX Cage and Rack Washer is a heavy duty, large capacity, hydro-spray washer designed for thorough, efficient cleaning of cages, racks, debris pans, and miscellaneous items used in the care of laboratory animals. Shallow sump design.



Size:

Compartment: 46" wide x 85" high x 92" long

Overall Unit: 84" wide x 100" high x 100" long

Sump Height: 6" high

Note: Washer can be designed to any size to meet new or existing applications. (Overall size may vary depending on chosen options)

Standard Features:

- Modular Construction
- Knock-down Shipment
- Oscillating Spray Jet System
- Personnel Safety Features
- Micro-computer Control System with Modem Package
- Automatic Ten-phase Treatment Cycle
- Automatic Self-cleaning Screen
- Temperature Guarantee
- Insulated Construction
- Incoming Utility Gauges
- Interior Illumination
- S/S Recirculation Piping and Components

Construction:

- All Stainless Steel Construction
- Automatic Water Level Control
- 10 HP Treatment Pump
- Stainless Steel Steam Coil Heating
- Touch Screen Operator Interface
- Programmable Cycles
- Direct Read Pump Pressure Gauge
- Double-pane Glass Window

Accessories:

- Floor Ramps
- Modular Walls
- Barrier Wall Flange(s)
- Bottle Wash Cart
- Universal Cage Wash Cart

Washing • Disinfection • Filling • Conveying



Utilities: 495LX

E	Electrical	3-60-208/230/460 V	12 HP	
S	Steam	2" NPT	35-80 PSI	Dynamic ± 5 PSI 600 #/Hr Flow Rate (1200 #/Hr with optional HW Heat Exchanger) 50 GPM @ 140 °F ± 5 °F
HW	Hot Water	1½" NPT	35 PSI	
C	Condensate	1" NPT		
D	Drain	4" Floor Drain (Minimum)	120 GPM	Flow Rate @ 200 °F
V	Vent	12" ID Duct	450 CFM	Saturated Vapor @ 190 °F
A	Air	½" NPT	100 PSI	6 CFM Flow Rate
CW*	Cold Water	1½" NPT	35 PSI	60 GPM @ 50 °F ± 5 °F

*CW – Required if drain discharge cool-down package is ordered

Optional Features:

- LYNX OPTI-Wash™ System
- Pit or Floor Mounted
- Right or Left Hand Services
- Re-usable Throwaway Alkaline and/or Acid Tanks
- House Hot Water Heat Exchanger
- Low Steam Pressure Package
- Integral Data Collection System
- LYNX Smart-Cool™ System
- Automatic Damper
- Pass-thru Unit
- Drain Discharge Cool Down/Tank
- Feeder Bottle Washing System
- Pan Washing
- Automatic Watering Rack Flush System
- Pass-thru Door Interlock System
- Split Base for Special Entry
- Air Compressor
- Exhaust Fan
- Strip Chart Printer
- Electric Heat System
- Utility Enclosure Panels
- Detergent Dispensing Systems
- pH Neutralization System
- Seismic Tie Down

NOTE: ADD 6" TO THE OPENING HEIGHT FOR FLOOR MOUNTED MACHINE

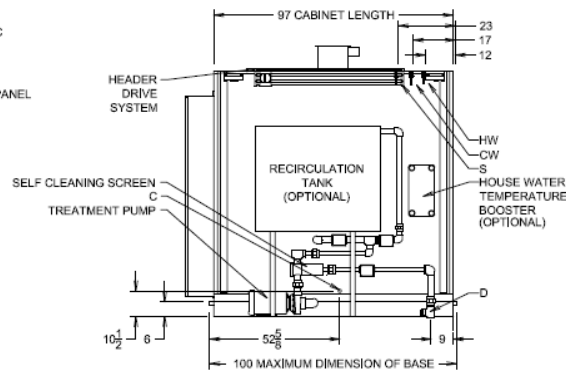
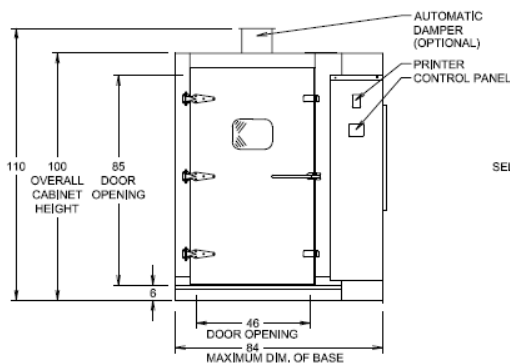
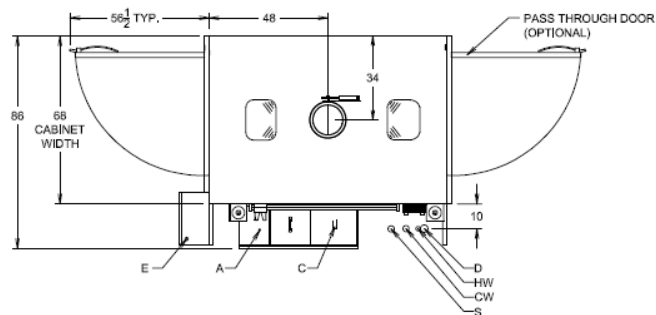
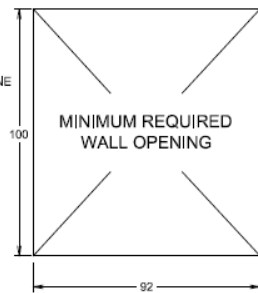

• Specifications are subject to change



LYNX Product Group
650 Lake Street
Wilson, NY 14172
716.751.3100 / 3101(fax)

For further information, please contact:

lynxpg.com

info@lynxpg.com • service@lynxpg.com
parts@lynxpg.com

Rev 013015